

Effect of Nozzle Pressure Ratio and Control Jets Location to Control Base Pressure in Suddenly Expanded Flows

K. A. Pathan^{1†}, P. S. Dabeer¹ and S. A. Khan²

¹ Trinity College of Engineering and Research, Pune, Maharashtra, 411048, India

² Department of Mechanical Engineering., Faculty of Engineering, International Islamic University Malaysia, Kuala Lumpur, Selangor, 50728, Malaysia

†Corresponding Author Email: kn.pathan@gmail.com

(Received August 3, 2018; accepted December 7, 2018)

ABSTRACT

In this paper, computational fluid dynamic (CFD) analysis and experiments have been carried out to study the effect of nozzle pressure ratio, i.e. the ratio of inlet pressure to atmospheric pressure, and the pitch circle diameter of the control jets to regulate the base pressure. The variables considered for the analysis as well as the experiments are the nozzle pressure ratio (NPR), the Mach number (M) and the pitch circle diameter (PCD) of the control jets. The area ratio considered for the study is kept constant at 4.84 while the length to diameter (L/D) ratio of an enlarged duct is set constant at 5. The inertia parameter considered for the study is Mach number. The Mach numbers considered for study are 1.5, 2.0, and 2.5. The nozzle pressure ratio considered for study are 2, 5 and 8. Three different pitch circle diameters of control jets considered for study are 13.1 mm, 16.2 mm and 19.3 mm. From the numerical simulations and the results of the experimental tests, it is found that the control jets are very beneficial to increase the base pressure at higher NPR when the jets issuing from the nozzles are under-expanded. The control jets were able to increase the base pressure value from 160% to 400% at nozzle pressure ratio 8. It is concluded that the parameter D_3 is the most effective pitch circle diameter of the control jets to increase the base pressure.

Keywords: Base pressure; Mach number; PCD of control jets; Nozzle pressure ratio.

NOMENCLATURE

AR	area ratio	M	Mach Number
CFD	Computational Fluid Dynamics	NPR	nozzle pressure ratio
C-D	Converging Diverging	P_a	atmospheric pressure
C	difference of radii of enlarged duct and nozzle exit	P_b	base pressure
D	enlarge duct diameter	T	input temperature
d_e	nozzle exit diameter	T_0	reference temperature
d_i	nozzle inlet diameter	T_s	sutherland's constant (for air 120 K)
d_t	nozzle throat diameter		
L	enlarge duct length	μ_0	reference viscosity at reference temperature T_0
L_c	nozzle convergent length	μ	viscosity at input temperature T
L_d	nozzle divergent length		

1. INTRODUCTION

In suddenly expanded flows, due to the sudden increase in the area of the duct, the base pressure is sub-atmospheric in the base area of the duct which finally increases the base drag. The base pressure should be increased very close to the ambient atmospheric pressure to reduce the base drag. Aerodynamic base drag due to the sub-atmospheric

pressure at the base or backwards-facing step is a common problem associated with all the moving projectiles, rockets, missiles, and the launch vehicles. The aerodynamic base drag is undesirable as its contribution to the total drag is substantial. The reduction in the base drag is of immense help for space and defense programs. From the literature, it has been found that the wake formation at the blunt base area could be similar to the nose length

of the fuselage/rockets/missile in the sub-sonic/sonic flow. However, in case of supersonic flow, the length of the wake region may be shorter as compared to the sonic flow due to the flow deflection because of the Mach wave, expansion wave or the oblique shock waves. The flow in the base region gets deflected away or towards the base depending upon the level of expansion.

This research work will be useful for space & defence industries and automobile industries as there is flow separation at the blunt base of the fuselage/rockets/missile/vehicle. In the modern automobile industries, the shape optimization has been given the utmost importance, and it is also considered as the thrust area of the research and development laboratories. Hence, these days the regulation of wake flow and the resulting resistance at the blunt base has become a significant field of investigation in the twenty-first century. The total drag consists of three components namely the wave drag, the skin friction drag, and the base drag. As far as the wave drag is concerned this area of research is already saturated. However, the skin friction is bound to be present due to the end user requirements of the payload carrying capacity (mission requirements/ requirements decided by the Army/Navy/Airforce).

The only component of the drag which is left for the research and being investigated is the base drag. The main reason for the base drag to be present is because of the low pressure in the base area of the projectile/missile/rocket/bomb/vehicle, which can be reduced by increasing the base pressure in the base region. The base pressure can be controlled by the active control method or a passive control method. The passive control involves the geometrical modifications while in the active control, the external source of energy is needed for the control mechanism or for the control jets which are employed in the base area.

In some cases like a rocket or missile, the base area cannot be changed, due to the presence of converging or converging-diverging nozzle positioned at the tail end of the system. However, in the case of shells and the aircraft, bombs, the base drag can be reduced by passive means by making the geometrical changes in the tail end by providing the boat tail or by implementing the step-body concept. The active control is typically used to regulate the base pressure and hence, to reduce the base drag during jet-off conditions of the rockets/missiles. In case of the rocket or the missile, the dead weight is not ejected after the powered phase. Whereas, in the case of the satellite launch vehicles immediately after the powered phase, the complete unit of the propulsion system or rocket motor is discarded to avoid the drag penalty during the remaining flight. However, in the case of unguided rockets and missiles, the dead weight remains with the system, to reduce the cost of the weaponry system. As the separation mechanism to discard the dead weight introduces the complications in the system as well as add the weight to the aerospace vehicle.

In the case of high-speed aerodynamics like missiles or rockets, the base pressure in the blunt base is very low due to the abrupt increase of the area and the shear layer exiting from the nozzle. Further, during the jet on conditions, the base drag is zero as the jet plume has huge momentum exiting from the nozzle. However, it is a considerable portion during the powered off conditions. The nature of the flow field with sudden expansion is shown in Fig. 1 (Khan *et al.* 2002).

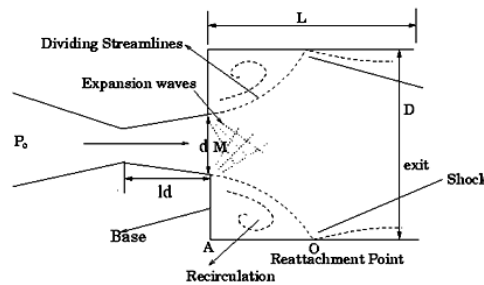


Fig. 1. Suddenly Expanded Flow Field.

Considering the importance of the problem in respect of the base drag the numbers of investigations have been done both theoretical and experimental. Due to the fast growth of interest in supersonic drag and the problems associated with, the development of supersonic/hypersonic aircraft, projectiles, missiles, and the spacecraft, the research interest has shifted to the prediction of the base drag very efficiently and accurately. Based on the above discussion, it is interesting to note that it is of paramount significance to regulate the flow field to get the desired results depending upon the applications.

From several existing studies (Khan & Rathakrishnan, 2003, 2004a, b, 2006a, b, c; Shafiqur & Khan, 2008; Khan 2016a, b; Maughal Ahmed Ali Baig *et al.* 2011, 2012; Fharukh and Khan 2016, 2018a), the effectiveness of microjets experimentally. The pitch circle diameter of the micro jets considered for all the cases was 13 mm. From their study, it has been found that microjets are useful to control the base pressure. Asadullah, *et al.* (2017, 2018a, b, c) have worked on a passive method to control the base pressure by the static and dynamic cylinder. The effectiveness of rotating cylinder of 2 mm diameter to control the base pressure has been investigated experimentally and from their tests it has been found that dynamic cylinders are capable of controlling the base pressure at high nozzle pressure ratios which is required for the correctly expanded case and the maximum gain in the base pressure is up to 65%.

Pathan *et al.* (2016, 2017a, b, c, 2018b) conducted the parametric simulation for the base pressure and its dependence on the geometrical parameters by the velocity distribution from the inlet up to the downstream of the nozzle and the circular duct. Their results indicate that the Mach number and nozzle pressure ratio regulates the flow development in the duct. The thrust generated by the nozzle flow depends on the area ratio, the NPR,

and the Mach number.

From the literature, it has been found that to control the base pressure, the control jets in the form of microjets are very useful. In literature, the pitch circle diameter of control jets was kept constant at 13 mm which is 1.3 times nozzle exit diameter. However, it is expected that for higher area ratios the pitch circle diameter should be increased concerning the area ratio to increase the effectiveness of the control jets. When the area ratio of the duct is increased by keeping PCD of control jets fixed, results in the marginal effectiveness of the active control. Since the control jets are near the main jet and they may propagate in the downstream without affecting the flow field in the base area.

Pathan *et al.* (2018a) have optimized the minimum area ratio required to get maximum thrust at a particular Mach number and nozzle pressure ratio. From their study, it can be seen that the area ratio should be increased with an increase in nozzle pressure ratio. At the nozzle pressure ratio from 2 to 8 and Mach number from 1.5 to 2.5 the minimum area ratio should be in the range of 4 to 6 to get maximum net thrust. Based on the literature, the area ratio considered for the present investigation is 4.84. Rathakrishnan & Srikanth (1991) studied the problem of flow in a pipe with a suddenly expanded duct. Based on their observations, it is possible to find an optimum length of the duct. Based on literature the length to diameter (L/D) ratio of the circular duct considered for the present study is held at 5 for all the cases. Concerning the difference between the radius of the enlarged duct and the nozzle exit radius, three different pitch circle diameters of the control jets are considered. Three pitch circle diameters of control jets as D_1 , D_2 , and D_3 , calculated from Eqs. (1), (2) and (3) are 13.1 mm, 16.2 mm and 19.3 mm respectively.

$$D_1 = d_e + 2 \times (0.25 \times C) \quad (1)$$

$$D_2 = d_e + 2 \times (0.50 \times C) \quad (2)$$

$$D_3 = d_e + 2 \times (0.75 \times C) \quad (3)$$

In the present study, the active control method is used to increase base pressure. This research work aims to enhance the pressure at the base and hence, to minimize the drag due to the low pressure at the base. In this investigation work, the air at high pressure from the control storage tank is introduced through the control jets in the base area of the enlarged duct using a regulating mechanism.

Total four numbers of control jets of 1 mm diameter individual are placed in the base area of the enlarged duct at an angle of 90 degrees to each other to control the base pressure. Three pitch circle diameters of control jets D_1 , D_2 and D_3 are considered independently to find the most effective pitch circle diameter. All the four control jets are used to blow the air in the base area from the control chamber. The readings of the base pressure were recorded for each location of control jets for all the cases of with and without control jets at different Mach numbers and nozzle pressure ratios.

This investigation covers the CFD analysis and validation of the CFD results by accompanying the experiments to ascertain the effectiveness of the control jets location to control the base pressure.

The investigations are carried out to study the effectiveness of the pitch circle diameter of control jets to increase the base pressure which is an additional advantage over the existing studies carried out in the literature.

2. CFD ANALYSIS

Computational fluid dynamics is a tool used to simulate the performance of any system involving fluid flow, heat transfer and other physical processes using the computer. It simulates fluid flow over the region of interest with specified boundary conditions by solving the equations. CFD implements a variety of technology including mathematics, computer science, engineering, and physics. The equations considered for a fluid flow analysis are continuity equation, momentum equation and energy equation are written in the Eqs. (4), (5), and (6) respectively.

$$\frac{\partial \rho}{\partial t} + \frac{\partial(\rho u_i)}{\partial x_i} = 0 \quad (4)$$

$$\frac{\partial(\rho u_i)}{\partial t} + \frac{\partial(\rho u_i u_j)}{\partial x_i} = \frac{\partial P}{\partial x_i} + \frac{\partial}{\partial x_i} \tau_{ij} \quad (5)$$

$$\frac{\partial}{\partial t} \left[\rho \left(e + \frac{V^2}{2} \right) \right] + \frac{\partial}{\partial x_j} \left[\rho u_j \left(e + \frac{V^2}{2} \right) + P + q_j - u_i \tau_{ij} \right] = 0 \quad (6)$$

Where,

u is instantaneous velocity,

V is velocity modulus,

ρ is gas density,

P is gas pressure,

q_j is heat flux and

τ_{ij} is viscous stress tensor.

The CFD is based on the fundamental governing equations of fluid dynamics – the continuity, the momentum, and the energy equations. They are the mathematical equations of three fundamental physical principles upon which all of fluid dynamics is based.

1. Mass is conserved. (Continuity equations)
2. Newton's second law. (Momentum equations)
3. Energy is conserved. (Energy equation)

Ansys workbench is used for CFD analysis. The geometry is shown in Fig. 2. The various geometries for all the cases are modeled according to geometrical parameters, and the nozzles are

considered for Mach numbers 1.5, 2.0 and 2.5. The dimensions of the nozzles for Mach numbers 1.5, 2.0 and 2.5 are shown in Table 1.

Table 1 Dimensions of nozzles

Parameter	Mach Number		
	1.5	2.0	2.5
Inlet Diameter (d_i)	19.94	25.90	28.00
Throat Diameter (d_t)	9.22	7.70	6.16
Exit Diameter (d_e)	10	10	10
Convergent Length (L_c)	20	25	30
Divergent Length (L_d)	14.88	13.16	18.28

All dimensions are in mm

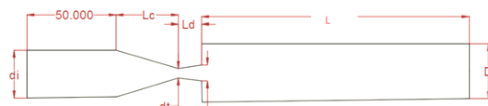


Fig. 2. Nozzle and an enlarged duct.

The diameter of the duct (D) for an area ratio of 4.84 is 22 mm. The enlarged duct length (L) is kept constant as five times the diameter of the duct which is equal to 110 mm.

The mesh element count should be optimum to complete the CFD analysis within a reasonable time and accuracy. The element count can reduce using hexahedral mesh elements instead of tetrahedral elements. The entire hexahedral mesh is generated by dividing the geometry into some sections, and each section has meshed separately with hexahedral meshing scheme. Fig. 3 shows the meshed model with hexahedral elements.

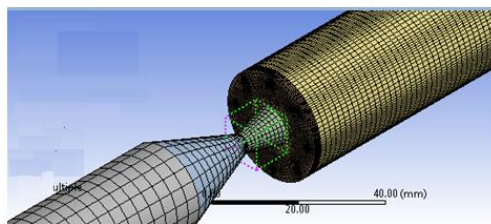


Fig. 3. Hexahedral structured meshed model.

The CFD analysis has numerous assumptions and the considerations that need to be considered for the better accuracy of the results. $k-\omega$ turbulence model is used for the analysis. The inlet boundary condition defined in Ansys Fluent is pressure inlet, and the outlet is defined as pressure outlet. The inlet pressure is calculated as per nozzle pressure ratio, and the outlet pressure is set to zero gauge pressure. The nozzle pressure ratios considered for CFD analysis are 2.0, 5.0 and 8.0. The density-based steady state solver is used in CFD analysis.

3. FABRICATION AND EXPERIMENTATION

Nozzles are fabricated for Mach numbers 1.5, 2.0 and 2.5. A sample drawing of the nozzle for Mach number 1.5 is shown in Fig. 4.

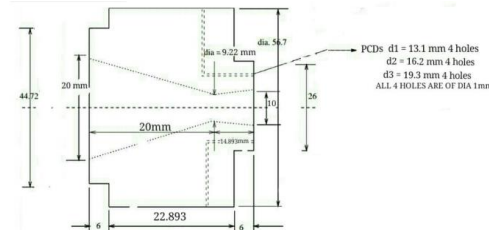


Fig. 4. Nozzle drawing for Mach number 1.5.

The nozzles were fabricated using the brass material on a CNC Lathe Machine. The position for the 1 mm holes for the control jets was marked using vertical machining center, and the holes were drilled using the radial drilling machine as shown in Fig. 5.



Fig. 5. Drilling holes for control jets on a radial drilling machine.

Figure 6 shows fabricated nozzles for different Mach numbers. All the nozzles were coupled to the MS flanges with the help of Allen screws.



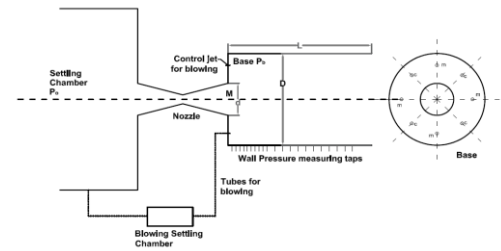
Fig. 6. Fabricated nozzles for Mach numbers 1.5, 2.0 and 2.5.

The brass pipe of diameter 22 mm was selected as the expansion duct and was brazed with the MS flange as shown in Fig. 7. The enlarged duct was then coupled to the nozzle flange using nuts and bolts.

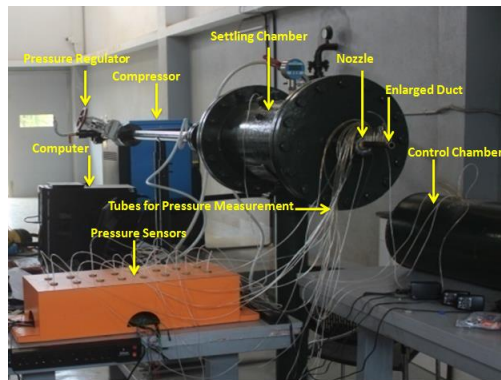


Fig. 7. Brazing of the enlarged duct with MS flange.

Figures 8(a) and (b) shows the block diagram of the experimental setup and the actual experimental setup respectively.



a) Experimental block diagram



b) Experimental Setup

Fig. 8. Experimental setup.

A screw air compressor with a discharge of 1.5 m³/min of dry air at a pressure of 12.5 bar, driven by a 15 kW 3-phase induction motor is used to compress the air. The compressed air was stored in the two storage tanks having capacities of 55 m³ at 20 bar pressure. The dry compressed air is then supplied to the settling chamber through a pressure regulating valve as per the required nozzle pressure ratio. From the settling chamber, the air passes through the nozzle and then exiting to the atmosphere through an enlarged duct. The air for the active control is being drawn from the main settling chamber to the control chamber. The air from the control chamber is supplied to the control jets. The pressures in the regulating chamber and the pressure under the stagnation conditions in the main settling chamber are the same.

During experimentation, when the flow becomes steady, the settling chamber pressure was recorded. At steady flow conditions, the base pressure in the duct was recorded by pressure transducers. Pressure transducer 9205 is used for measuring the pressure in the base area, wall pressure, and the stagnation pressure in the settling chamber of the experimental setup. The LabVIEW software along with DAQ acquires the data at the rate of 350 samples per second. It takes an average of all the samples and displays the readings from all the measuring point at a time on the screen of the computer.

As long as the flow is sub-sonic or sonic, the main

jet/flow exiting from the converging nozzles is always correctly expanded. However, in the case of supersonic flow, when the flow is coming out from the converging-diverging nozzle, there can be three conditions. The main jet may be correctly expanded, over expanded or under-expanded. In the present study, the main jet/flow from the nozzle for Mach numbers 1.5 and 2.0 is tested for all the levels of expansion from over-expanded to under-expanded. For Mach number 2.5 only over expanded conditions are studied as the requirement of the nozzle pressure ratio to correctly expand the main jet is 17.09 which is very high and not possible to conduct the tests due to the limitation of the experimental setup, limitation of the storage tanks and the capacity of the compressor. For under expanded conditions at Mach number 2.5 more than 17.09 NPR is required. The nozzle pressure ratio required to correctly expand the main jet/flow from the nozzle at any Mach number can be calculated using Eq. (7) (Ethirajan Rathakrishnan, 2011). The nozzle pressure ratio required to correctly expand the main jet at Mach numbers 1.5 and 2.0 are 3.67 and 7.82 respectively.

$$NPR_{req} = \left(1 + \left(\frac{\gamma - 1}{2} \right) \times M^2 \right)^{\frac{\gamma}{\gamma - 1}} \quad (7)$$

Where, $\gamma = 1.4$ for air

4. RESULTS AND DISCUSSION

The CFD results were extracted with the help of ANSYS Fluent post-processing. Different contours for total pressure and velocity are shown in Figs. 9 to 16.

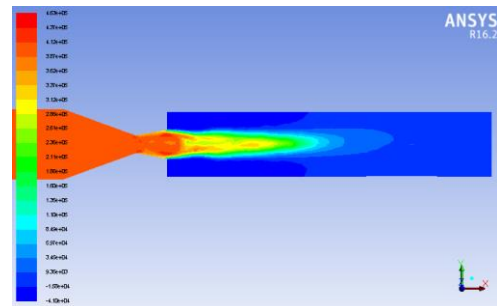


Fig. 9. Pressure contour for $M = 2.5$, $NPR = 5$ without control jets.

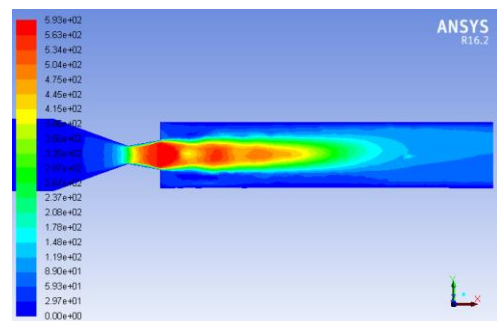


Fig. 10. Velocity contour for $M = 2.5$, $NPR = 5$ without control jets.

From Figs. 9 to 16 it is seen that the control jets are very efficient to increase the base pressure at the higher level. Further, it is seen that the flow from control jets does not alter the main flow from the nozzle. Also, it is seen that the wall pressure in the circular duct is identical with and without control.

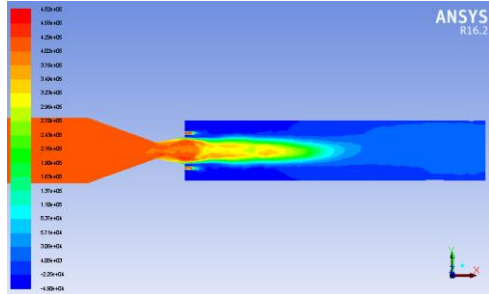


Fig. 11. Pressure contour for $M = 2.5$, $NPR = 5$ and $PCD = D_1$.

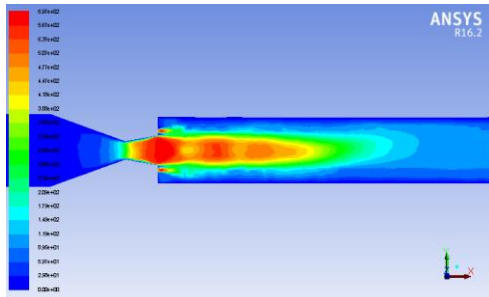


Fig. 12. Velocity contour for $M = 2.5$, $NPR = 5$ and $PCD = D_1$.

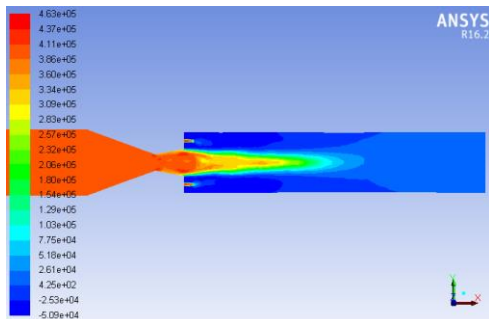


Fig. 13. Pressure contour for $M = 2.5$, $NPR = 5$ and $PCD = D_2$.

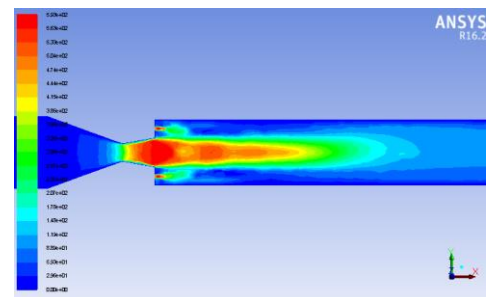


Fig. 14. Velocity contour for $M = 2.5$, $NPR = 5$ and $PCD = D_2$.

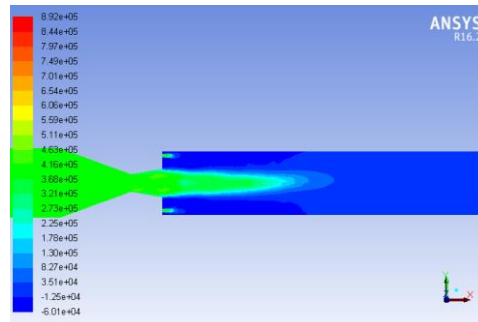


Fig. 15. Pressure contour for $M = 2.5$, $NPR = 5$ and $PCD = D_3$.

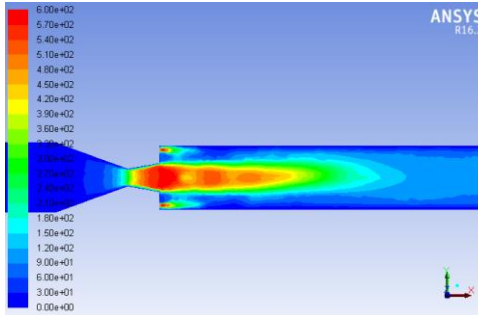


Fig. 16. Velocity contour for $M = 2.5$, $NPR = 5$ and $PCD = D_3$.

4.1 CFD Analysis and Experimental Results

The total average base pressure is measured on the base face of the duct with the help of ANSYS fluent postprocessor. All the values of the base pressure are the gauge pressure, and it should be converted into the absolute pressure by adding the ambient atmospheric pressure. Then the absolute pressure is divided by atmospheric pressure to convert into dimensionless base pressure.

Figures 17 to 19 show the CFD analysis and experimental results for the dimensionless base pressure vs nozzle pressure ratio (NPR) for three pitch circle diameters of control jets D_1 , D_2 and D_3 at different Mach numbers. The results indicate that the base pressure obtained experimentally is higher as compared to the CFD results. These variations in the experimental and CFD results are within 10 per cent band which is fair enough.

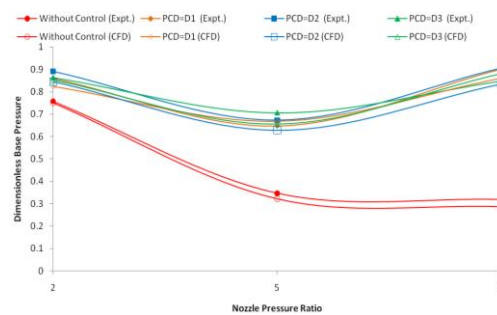


Fig. 17. P_b/P_a vs. NPR for $M = 1.5$.

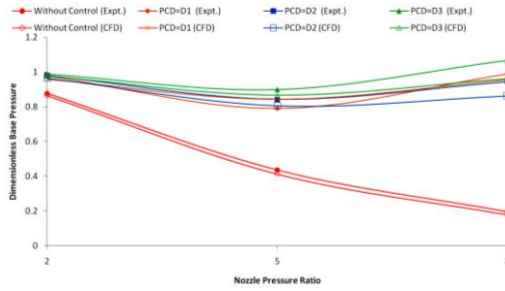


Fig. 18. P_b/P_a vs. NPR for $M = 2.0$.

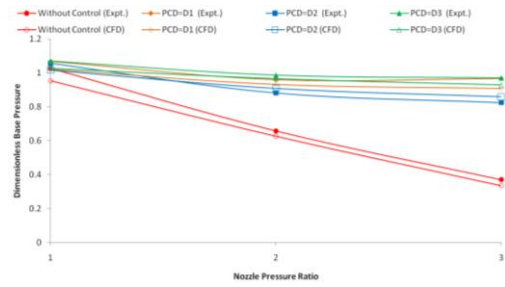


Fig. 19. P_b/P_a vs. NPR for $M = 2.5$.

From the Figs. 17 to 19 it is seen that the base pressure without control for all the nozzle pressure ratio is lower than the base pressure with control jets. With the enhancement in the NPR values, the flow from the nozzle is under the influence of a favorable pressure gradient and because of the high level of expansion and the inertia values, the base pressure is reduced. Based on the results, it has been found that the control jets are useful at all the pitch circle diameters. The most effective pitch circle diameter of control jets which increases the base pressure at all the nozzle pressure ratios is D_3 . It is observed that the control jets are very useful at the higher nozzle pressure ratios.

Figures 20 to 22 show the percentage change in the base pressure with flow regulation mechanism at different pitch circle diameters of the control jets for nozzle pressure ratios 2, 5, and 8. The percentage increase is taken as an average of the CFD results and the experimental results.

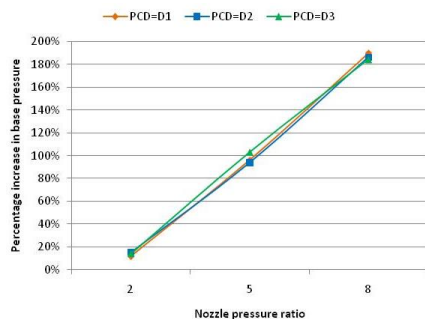


Fig. 20. Percentage change in base pressure for $M = 1.5$.

From Figs. 20 to 22 it is seen that the effectiveness of control jets increases with the increment in the nozzle pressure ratio. It is also observed that at the nozzle pressure ratio (NPR) = 8, the minimum

increase in the base pressure is approximately up to 160% at Mach number 2.5, this increase in the base pressure reaches about 400% for Mach number 2.0 when compared by the without control cases.

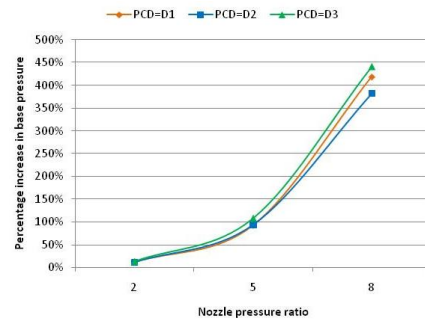


Fig. 21. Percentage change in base pressure for $M = 2.0$.

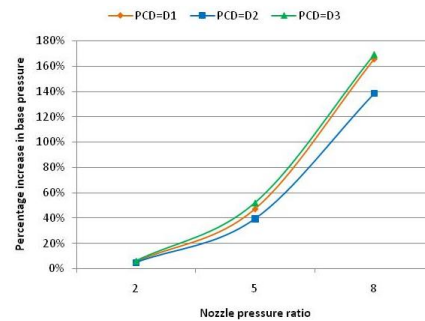


Fig. 22. Percentage change in base pressure for $M = 2.5$.

From Figs. 20 to 22, the control mechanism is most efficient at Mach number is equal to 2.0 and NPR = 8. Because at Mach number 1.5 due to low inertia level the reattachment length is small which results in smaller recirculation zone. Hence the scope to increase base pressure using control jets is less since the control jets have intersected the recirculation zone and joined with main flow. Therefore the control jets are less effective as compared with the effectiveness of control jets at Mach number $M = 2.0$. For Mach number $M = 2.5$, the nozzle remains over expanded at all the nozzle pressure ratios of this study. For the over-expanded nozzle, and the lower L/D ratios, the flow does not reattach to the enlarged duct. Hence the base pressure is not reduced to lower values if compared with base pressure in case of Mach number 2.0. Hence the control jets are less effective at Mach number 2.5 as compared to the effectiveness of control jets at Mach number 2.0.

Based on the above results and discussions it can be stated that D_3 is the most effective pitch circle diameter of control jets to increase the base pressure. Figure 23 shows the wall pressure along the duct length.

From Fig. 23 it is found that for Mach numbers 1.5, 2.0 and 2.5 at lower nozzle pressure ratio, i.e. NPR=2, the nozzle becomes over expanded and the flow from the nozzle have more considerable reattachment lengths. From Fig. 23 at Mach number

1.5 and nozzle pressure ratio five and eight, sudden peak is observed in the pressure value at a distance of 27 mm from nozzle exit, this means that the main jet has become under-expanded, and the main flow is reattached to the enlarged duct at a distance of 27 mm from the nozzle exit.

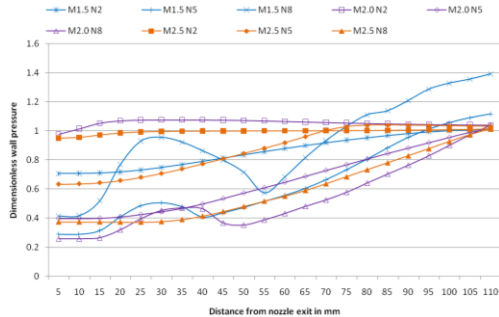


Fig. 23. Wall pressure distribution along the length of the duct.

NPR required for correctly expanded the main jet at Mach number 2.0 is 7.82. From Fig. 23 it is noted that at $M = 2.0$ and nozzle pressure ratio 2 and 5 the main jet is over-expanded, and the main flow reattached at more significant lengths as compared to the case when the flow is under-expanded. However, at $NPR = 8$, the nozzle becomes under-expanded, and flow gets reattached with the duct at a distance of 37 mm from nozzle exit. For Mach number 2.5, the flow from the nozzle is over-expanded at all nozzle pressure ratios and, the considerable duct length is required to reattach the main flow with the duct wall.

It is seen that the nozzle pressure ratio has a direct impact on the base pressure. With the decrease in the level of over-expansion, the nozzle flow tends to become correctly expanded and later under-expanded and hence improves the efficacy of the control mechanism. It can be stated that with enhancement in nozzle pressure ratio, the base pressure tends to get reduced for all the nozzle pressure ratios at all the parameters of the present investigation.

5. CONCLUSIONS

From the results obtained by the CFD simulations and experimentation; the following conclusions can be drawn.

- It is found that the control jets are useful to improve the base pressure at all the pitch circle diameters, but D_3 seems to be the most effective pitch circle diameter of the control jets to increase the base pressure as compared with the other locations.
- The numerical simulation results, as well as the experimental results, indicate that the level of expansion (NPR) and the inertia level available at the nozzle exit (Mach number) has a significant role to manipulate the base pressure.

- The results indicate that the control is very effective whenever the flow from the nozzles is under expanded as the control of a jet under the influence of a favorable pressure gradient is very efficient.

The present study is a technology demonstration. This study generates a database which can be useful for space research program. If an application is for the combustion chamber, then the results from the database can be used for the combinations of the parameters which gives minimum base pressure. If the applications are for external aerodynamics, then the researcher can select those combinations of parameters which can give maximum base pressure and hence minimum base drag. The problem and the results cannot be generalized since the waves dominate the supersonic flow. Hence the researcher has to select the combinations of the flow and geometrical parameters on a case to case basis.

REFERENCES

- Asadullah, M., S. A. Khan, W. Asrar and E Sulaeman (2017). Active control of base pressure with counter-clockwise rotating cylinder at Mach 2. *4th IEEE International Conference on Engineering Technologies and Applied Sciences (ICETAS)* (pp. 1-6). Salmabad, IEEE, pp. 1-6.
- Asadullah, M. S. A. Khan, W. Asrar and E Sulaeman (2018a). Passive control of base pressure with static cylinder at supersonic flow. *IOP Publishing House, IOP Conf. Series: Materials Science and Engineering* 370, 1-10.
- Asadullah, M., S. A. Khan, W. Asrar and E Sulaeman (2018b). Counter Clockwise Rotation of Cylinder with Variable Position to Control Base Flows. *IOP Publishing House, IOP Conf. Series: Materials Science and Engineering* 370, 1-10.
- Asadullah, M. S. A. Khan, W. Asrar and E Sulaeman (2018c). Low-Cost Base Drag Reduction Technique. *International Journal of Mechanical Engineering and Robotics Research* 7(4)
- Baig M. A. A., F. Al-Mufadi, S. A. Khan and E. Rathakrishnan (2011). Control of Base Flows with Micro Jets. *International Journal of Turbo and Jet Engines (IJT)* 28(1), 59-69.
- Baig M. A. A., F. Al-Mufadi, S. A. Khan and E. Rathakrishnan (2012). Control of base flows with micro jet for area ratio of 6.25. *ARNP Journal of Engineering and Applied Sciences* 7(8), 992-1102.
- Ethirajan R. (2011). *Gas Dynamics*. Third ed. PHI Learning Private Limited, New Delhi, India.
- Fharrukh A. G. M. and S. A. Khan (2018). Investigation of efficacy of low length-to-diameter ratio and nozzle pressure ratio on base pressure in an abruptly expanded flow.

MATEC Web of Conferences 172, 01004.

- Fharukh, A. G. M., Mohammad A. U. and S. A. Khan (2016). Experimental Study of Suddenly Expanded Flow from Correctly Expanded Nozzles. *ARPJ Journal of Engineering and Applied Sciences* 11(16), 10041-10047.
- Khan, S. A., and E. Rathakrishnan (2006a). Nozzle expansion level effect on suddenly expanded flow. *International Journal of Turbo and Jet Engines* 23, 233-257.
- Khan, S. A. and E. Rathakrishnan (2006b). Control of Suddenly Expanded Flow. *International Journal of Aircraft Engineering and Aerospace Technology (AEAT)* 78(4), 293-309.
- Khan, S. A. and E. Rathakrishnan (2006c). Active Control of Base Pressure in Supersonic Regime. *Journal of Aerospace Engineering, Institution of Engineers, India, Volume 87*, 1-8.
- Khan, S. A. and E. Rathakrishnan(2002). Active control of suddenly expanded flows from over expanded nozzles. *International Journal of Turbo and Jet Engines* 19, 119-126.
- Khan, S. A., A. Mohammed, and J. Sadhiq (2018a). Passive Control of Base Drag Employing Dimple in Subsonic Suddenly Expanded Flow. *International Journal of Mechanical & Mechatronics Engineering IJMME-IJENS* 18(03), 69-74.
- Khan, S. A., A. Mohammad, A. G. M. Fharukh, J. Ahmed and Baig M. A. A. (2018c). Passive Control of Base Drag in Compressible Sonic Flow Using Multiple Cavity. *International Journal of Mechanical and Production Engineering Research and Development IJMPERED*, 8(4), 39-44.
- Khan, S. A., A. Aabid and M. A. A. Baig. (2018d). CFD Analysis of CD Nozzle and Effect of Nozzle Pressure Ratio on Pressure and Velocity for Suddenly Expanded Flows. *International Journal of Mechanical and Production Engineering Research and Development IJMPERED* 8(3), 1147-1158.
- Khan, S. A., M. A. Fatehpurwala, K. A. Pathan, P. S. Dabeer and M. A. A. Baig (2018e). CFD Analysis of Human Powered Submarine to Minimize Drag. *International Journal of Mechanical and Production Engineering Research and Development IJMPERED* 8(3), 1057-1066.
- Khan, S. A., and E. Rathakrishnan (2003). Control of suddenly expanded flows with micro jets. *International Journal of Turbo and Jet Engines* 20, 63-81.
- Khan, S. A., and E. Rathakrishnan (2004a). Active control of suddenly expanded flows from under expanded nozzles. *International Journal of Turbo and Jet Engines* 21, 233-253.
- Khan, S. A., and E. Rathakrishnan (2004b). Control of suddenly expanded flows from correctly expanded nozzles. *International Journal of Turbo and Jet Engines* 21, 255-278.
- Pathan K. A., P. S. Dabeer and S. A. Khan (2018a). Optimization of Area Ratio and Thrust in Suddenly Expanded Flow at Supersonic Mach Numbers. *Case Studies in Thermal Engineering* 12 696–700
- Pathan, K. A., Dabeer P. S. and S. A. Khan (2016). CFD Analysis of the Supersonic Nozzle Flow with Sudden Expansion. *International Organization of Scientific Research-Journal of Mechanical and Civil Engineering (IOSR-JMCE)* 4, 05-07.
- Pathan, K. A., Dabeer P. S. and S. A. Khan (2017a). CFD analysis of effect of area ratio on suddenly expanded flows. *2017 2nd International Conference for Convergence in Technology (I2CT)*. Mumbai: IEEE, 1192-1198.
- Pathan, K. A., Dabeer P. S. and S. A. Khan (2017b). CFD analysis of effect of flow and geometry parameters on thrust force created by flow from nozzle. *2017 2nd International Conference for Convergence in Technology (I2CT)*. Mumbai: IEEE, 1121-1125.
- Pathan, K. A., Dabeer P. S. and S. A. Khan (2017c). CFD analysis of effect of Mach number, area ratio and nozzle pressure ratio on velocity for suddenly expanded flows. *2017 2nd International Conference for Convergence in Technology (I2CT)*. Mumbai: IEEE, 1104-1110.
- Pathan, K. A., Dabeer P. S. and S. A. Khan (2018a). An Investigation to Control Base Pressure in Suddenly Expanded Flows. *International Review of Aerospace Engineering (I.RE.AS.E)* 11(4), pp. 162-169.
- Pathan, K. A., Dabeer P. S. and S. A. Khan (2018b). An Investigation to Control Base Pressure in Suddenly Expanded Flows. *International Review of Aerospace Engineering (I.RE.AS.E)* 11(4), 162-169.
- Rathakrishnan, E. and R. Srikanth (1991). Flow Through Pipes with Sudden Enlargement. *Mechanics Research Communications* 18 (4), 199-206.
- Shafiqur, R. and Khan, S. A. (2008). Control of Base Pressure with Micro Jets Part-I. *Aircraft Engineering and Aerospace Technology: An International Journal (AEAT)* 80(2), 158-164.