

Effect of Channel Boundary Conditions in Predicting Hydraulic Jump Characteristics using an ANFIS-Based Approach

K. Roushangar[†], R. Ghasempour and R. Valizadeh

Faculty of Civil Engineering, University of Tabriz, Tabriz, Iran

[†]Corresponding Author Email: kroshangar@yahoo.com

(Received May 1, 2017; accepted December 12, 2017)

ABSTRACT

Hydraulic jump is a phenomenon which is used to dissipate the kinetic energy of the flow and prevent scour below overflow spillways, chutes and sluices. This paper applies adaptive neuro-fuzzy inference system (ANFIS) as a Meta model approach to estimate hydraulic jump characteristics in channels with different bed conditions (i.e. channels with different shapes and appurtenances). In hydraulic jump characteristics modeling, different input combinations were developed and tested using 1700 experimental data. The obtained results indicated that the applied method has high capability in modeling hydraulic jump characteristics. It was observed that the developed models for expanding channel with a block performed more successful than other channels. For rectangular channels, it was found that the basin with rough bed led to better predictions compared to the basin with a step. In the prediction of jump length, the superior performance was obtained for the model with input combinations of Froude number and the relative height of jump. From the sensitivity analysis, it was induced that, Fr_1 (upstream Froude number) is the most significant parameter in modeling process. Also comparison between ANFIS and semi-empirical equations indicated the great performance of the ANFIS.

Keywords: ANFIS; Boundary conditions; Expanding channels; Hydraulic jump characteristics; Rough bed.

NOMENCLATURE

b_1	amplitude of oscillation	w/ks	pitch ratio
b_2	cylinder diameter	Y	sequent depth ratio
B	ratio of expansion	y_1	upstream flow depth
Fr_1	upatream Froude number	y_2	downstream flow depth
g	acceleration due to gravity	z	height of the step or sill
ks	bed roughness height		
L_j	length of jump	μ	dynamic viscosity of water
R	flow Reynolds number	ρ	density of water
V_1	upstream flow velocity		

1. INTRODUCTION

Hydraulic jump is a phenomenon which occurs when supercritical flow is forced to change to subcritical. Hydraulic jump is used to prevent scouring downstream from the hydraulic structures by dissipating excess energy in water flowing over these structures. During hydraulic jump, intense mixing, air entrainment and rapid rise of depth occurs. Therefore, it can also be used for raising the water level, mixing chemicals in streams, desalinating the sea water and aerating

streams which are polluted by biodegradable wastes. Depending on the geometry of channel and tailwater conditions, the hydraulic jump can assume several distinct forms. The performance or efficiency of any stilling basin is usually assessed in terms of hydraulic jump characteristics (Negm, 2000). In stilling basins different appurtenances have been used to dissipate the kinetic energy, such as chute blocks, baffle piers and a central block. Due to significant impact of hydraulic jump characteristics on hydraulic structures planning, designing and management, therefor, accurate

Table 1 The range of experimental data

Channel type	Researcher	Fr ₁	B (b ₂ /b ₁)	Y(y ₂ /y ₁)	ks (cm)	Z/y ₁	No. of data
Channel without appurtenances							
Rectangular channel with smooth bed	Bhutto (1987)	1.33-15.7	-	0.96-21.8	-	-	120
	Carollo <i>et al.</i> (2007)	1.87-8.78	-	2.3-10.5	-	-	72
Expanding channel with smooth bed	Bremen (1990)	2.63-8.13	1.5, 3, 5	2.02-12.05	-	-	431
Channel with appurtenances							
Rectangular channel with rough bed	Carollo <i>et al.</i> (2007)	0.1-10	-	2.8-10	0.46-3.2	-	300
Rectangular channel with step	Sultana (2011)	1.09-3.8	-	3.68-9.95	-	0.57-3.75	108
Trapezoidal channel with rough bed	Evcimen (2012)	3.92-13.28	-	4.15-14.91	1-3	0.37-2.2	107
Expanding channel with step	Bremen (1990)	2.05-8.43	1.5, 2, 3	1.45-12.59	-	0.49-1.66	346
Expanding channel with central block	Bremen (1990)	3,5,7,9	1.5, 2, 3	2.89-10.63	-	0.6-3	213

Note: Fr₁: Froude number, Y: sequent depth ratio, y₁: upstream flow depth, y₂: downstream flow depth, B: ratio of expansion, b₁: amplitude of oscillation, b₂: cylinder diameter, ks: bed roughness height, Z: height of the step or sill

estimation of these characteristics is important. Various studies have been conducted to explain the complex phenomenon of the hydraulic jump and to estimate its characteristics. Bhutto *et al.* (1989) investigated the characteristics of a free hydraulic jump in sloping and horizontal stilling basins. Negm (2000) studied the hydraulic performance of rectangular and radial stilling basins, where the latter stand for the diverging channels. Debabeche and Achour (2007) investigated the effect of a continuous block on hydraulic jump characteristic in a triangular channel. Ezizah *et al.* (2012) carried out some experiments to investigate the effect of U-shape roughness elements on hydraulic jump characteristics for Froude number range of 3 to 11. However, due to the complexity and uncertainty of the hydraulic jump phenomenon, the results of the classical models are not general and under different flow and channel geometry conditions, show different results. Hence, it is essential to use some other approaches which can estimate the hydraulic jump characteristics within the channels with different shapes more accurately.

The Meta model approaches such as Artificial Neural Networks (ANNs), Genetic Programming (GP) and Support Vector Machine (SVM), have been applied in investigating the hydraulic and hydrologic complex phenomena in recent decades. Modeling of suspended sediment concentration (Kisi and Shiri, 2012), prediction of scour caused by 2D horizontal jets (Karbasi and Azamathulla, 2016) and sediment transport prediction in circular channels (Roushangar and Ghasempour, 2016) are some examples of the Meta model approaches applications.

Among others, ANFIS technique has been applied for estimation of various hydraulic components. Kisi (2005) applied ANFIS for modeling of suspended sediment discharge. Ozger and Yildirim

(2009) used ANFIS method to investigate the relationship between pipe roughness, Reynolds number, and friction factor. Azamathulla *et al.* (2012) used ANFIS approach for modeling sediment transport in sewers. Talei (2010) used ANFIS method for modeling rainfall-runoff process. Saxena and Yadav (2017) used ANFIS in capacity prediction for Ukai reservoir. Solgi *et al.* (2014) assessed the capability of ANFIS model in forecasting daily precipitation. Kerachian *et al.* (2006) used ANFIS approach to optimize the reservoir operation.

This study aimed to assess the performance of ANFIS method in modeling hydraulic jump characteristics in channels with different bed conditions (i.e. rectangular channel with smooth and rough bed, sloping channel with step, trapezoidal channel with rough bed and sudden expanding channels with step and central block). Due to find the most significant parameters in hydraulic jump characteristics modeling process, different input combination based on flow condition and appurtenances geometry were developed. Finally, the efficiency of the best ANFIS models was compared to some of the classic approaches.

2. MATERIALS AND METHODS

2.1 The used Data Series

In this study, four kinds of data corresponding to hydraulic jump, taken from published literature, are used. Details of these experimental data sets are listed in Table 1. The experiments of Bremen (1990) were carried out at the Laboratoire de Constructions Hydrauliques of the Ecole Polytechnique Federale de Lausanne (EPFL), which were intended for sudden diverging basins without appurtenances, with central sill and a negative step. A 0.5 m wide and 10.8 m long prismatic rectangular and horizontal channel was connected to the basin.

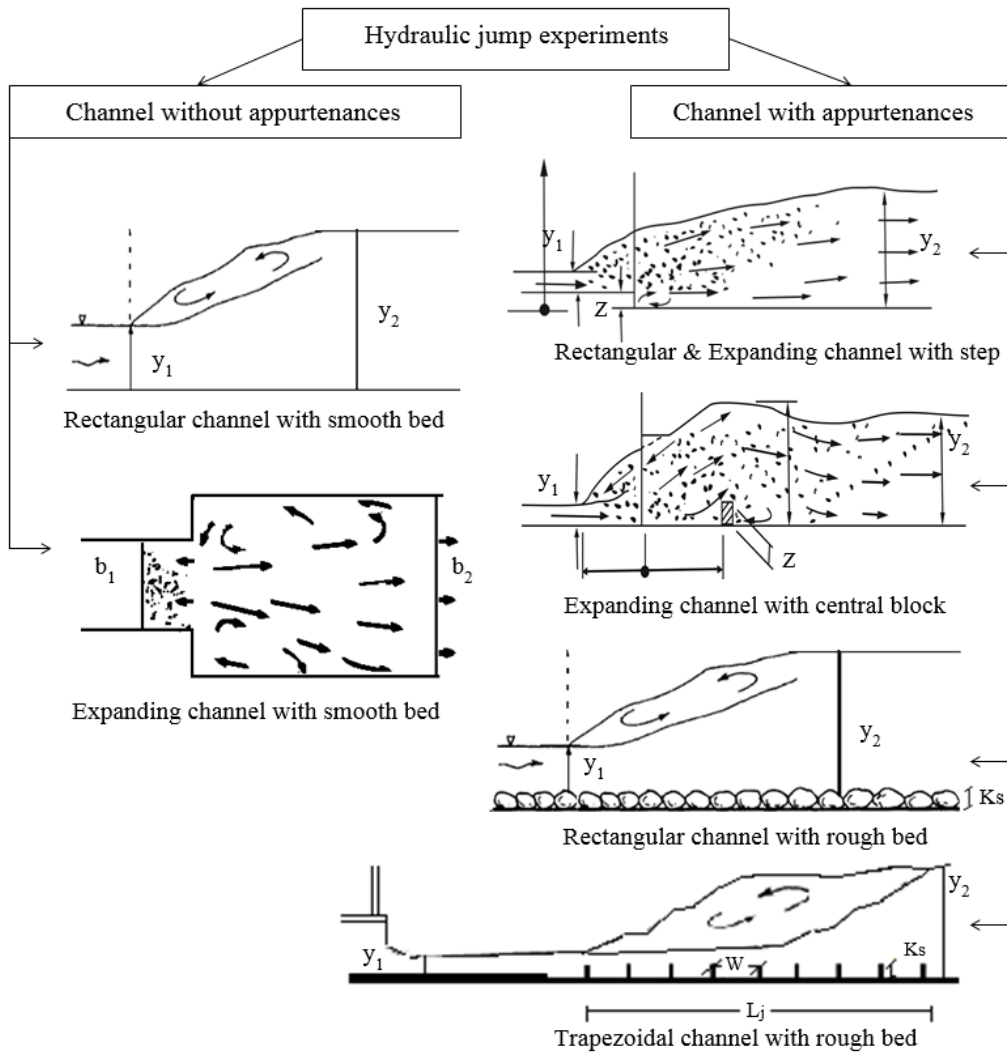

Fig. 1. Schematic view of the experiments of Table 1.

At the upstream channel extremity a standard shaped 0.50 m wide and 0.70 m high spillway of design head $H_0=0.2$ m controlled the channel inflow.

The experiments of [Carollo *et al.* \(2007\)](#) were done at a rectangular laboratory flume made up of glass. The sloping flume sized $14.4 \times 0.6 \times 0.6$ m. The experiments were done in both smooth and rough beds. For investigating the effect of rough bed on hydraulic jump properties, five rough beds made up of gravel particles were tested.

The experiments of [Sultana \(2011\)](#) were performed in the 40-ft long tilting flume in the laboratory. Three different slopes of 0.0042, 0.0083 and 0.0125 were maintained in the flume. A series of experiments were performed with a step height of 2, 4.5 and 6 cm.

The experiments of [Evcimen \(2012\)](#) were done in Hydromechanics Laboratory, METU. For the experimental setup, dimensions were selected as width of channel bed 32 cm and side angles 60° with vertical. The tests were done in a prismatic, symmetrical trapezoidal channel with depth of 0.26 m and length of 6 m. Both bed and side walls were

made up of five layers of plexiglass sheets. Three different sizes of fiberglass roughness elements were used in the experiments. The side view of the experimental channels is shown in Fig. 1.

2.2 Adaptive Neuro-Fuzzy Inference System (ANFIS)

Adaptive neuro-fuzzy inference systems (ANFIS) are considered as a kind of artificial neural networks which are based on Takagi–Sugeno fuzzy inference system. In this system different functions are applied to express the conclusions ([Takagi and Sugeno, 1985](#)). The base of Fuzzy logic method is condition–result rules. ANFIS merges the principles of neural networks and fuzzy logic; therefore, in a single framework it can take the advantages of both methods. ANFIS inference system corresponds to a set of fuzzy IF–THEN rules. The learning capability of these rules makes it possible to approximate nonlinear functions. A rule of this model can be expressed as:

$$\begin{aligned} &\text{If } x_1 \text{ is } A_1 \text{ and } x_2 \text{ is } A_2 \\ &\text{THEN } y = f(x_1, x_2, \dots, x_n) \end{aligned} \quad (1)$$

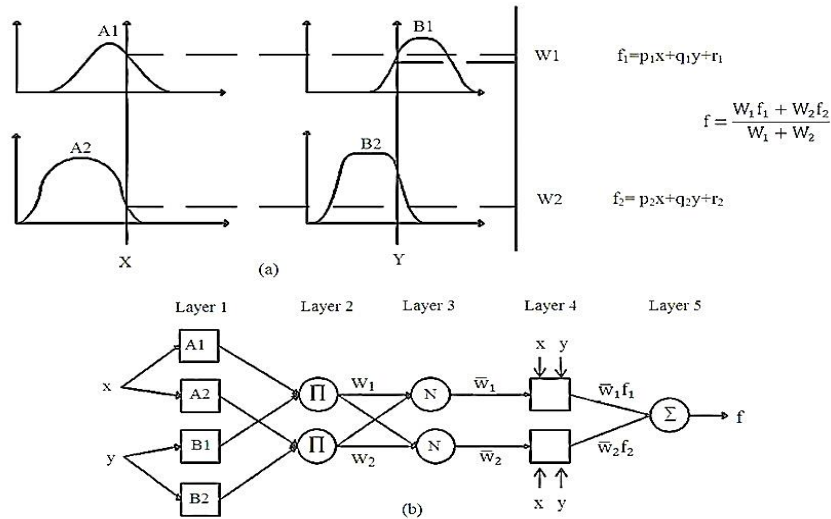

Fig. 2. Reasoning mechanism for Takagi-Sugeno model (a) and Scenario of ANFIS model (b).

Considering the fuzzy logic system with two inputs (x, y) and one output (y), the ordinary regulation set of the fuzzy system for first grade TS fuzzy model can be expressed in the form of two "if-then" laws, as follows:

Rule 1: if x is A_1 and y is B_1
 THEN $f_1 = p_1x + q_1y + r_1$ (2)

Rule 2: if x is A_2 and y is B_2
 THEN $f_2 = p_2x + q_2y + r_2$ (3)

The general structure of ANFIS method is illustrated in Fig. 2.

Layer 1: Every node is an Adaptive to a function parameter.

$$O_{1,i} = \mu_{A_i}(x), \dots, \text{for } i = 1, 2, \dots \text{ or} \quad (4)$$

$$O_{1,i} = \mu_{B_{i-1}}(y), \dots, \text{for } i = 3, 4 \quad (5)$$

A_i, B_{i-1} : Linguistic label which belongs to Node i .
 $O_{1,i}$: Membership grade.

Layer 2: Nodes of layer 2 are supposed as node Π , the output of which is calculated as Eq. (6):

$$O = \bar{w} = \frac{w_i}{w_1 + w_2}, \dots, i = 1, 2 \quad (6)$$

Layer 3: Layer 3 nodes are nonadaptive and are labeled as N . These nodes are calculated from the ratio between the i^{th} laws firing strength and the sum of all rules' firing strengths.

$$O = \bar{w} = \frac{w_i}{w_1 + w_2}, \dots, i = 1, 2 \quad (7)$$

Layer 4: Each "i" node in layer 4 is an adaptive node to an output:

$$O = \bar{w}f = \bar{w}(px + qy + r) \quad (8)$$

$$O = \sum \bar{w}f = \frac{\sum w_i f_i}{\sum w_i} \quad (9)$$

The ANFIS approaches were implemented using MATLAB in this study. The complete description of ANFIS can be found in Jang (1993).

2.3 Hydraulic Jump Characteristics Semi-Empirical Formulas

A variety of formulas have been extracted to assess hydraulic jump characteristics in channels and flumes. In extraction process of these formulas, different concepts and approaches are used (i.e. different assumptions, statistical correlations, a combination of the semi-empirical models and experimental information). However, these semi-empirical models often represent different results under variable conditions. Some of the existing hydraulic jump characteristics estimation equations are listed in Table 2.

2.4 Performance Criteria

In the current study, four statistical criteria were applied for assessing the models' performance, namely, Correlation Coefficient (R), Determination Coefficient (R^2), and Root Mean Square Error ($RMSE$), expressions for which are given as:

$$R^2 = 1 - \frac{\sum_{i=1}^N (l_o - l_p)^2}{\sum_{i=1}^N (l_o - \bar{l}_p)^2} \quad (20)$$

$$R = \frac{\sum_{i=1}^N (l_o - \bar{l}_o) \times (l_p - \bar{l}_p)}{\sqrt{\sum_{i=1}^N (l_o - \bar{l}_o)^2 \times (l_p - \bar{l}_p)^2}} \quad (21)$$

$$RMSE = \sqrt{\frac{\sum_{i=1}^N (l_o - l_p)^2}{N}} \quad (22)$$

Table 2 Hydraulic jump characteristics estimation equations

Researcher	Equation	Consideration	Equation number
Sudden expanding channel			
Kusnetzow (1958)	$Y = \frac{0.5}{B} K \left[\sqrt{1 + 8BFr} - 1 \right]$	$K_K = 0.8 - \left(0.9 - \frac{1}{B} \right) \times 0.15$ For free jump in expanding channel without appurtenances	(10)
Herbrand (1973)	$Y = F\eta \sqrt{\frac{2}{B} - \frac{1}{2B}}$	For free jump in expanding channel without appurtenances	(11)
Hager (1985)	$L_j = \left\{ 1 + \left(1 - \frac{1}{\sqrt{B}} \right) \times [1 - th(1.9X_1)] \right\} L_j^*$	$L_j^* = y_1 \times 220 \times th \left(\frac{F\eta - 1}{22} \right)$ For free jump in expanding channel without appurtenances	(12)
Peterka (1958)	$\frac{L_j}{y_1} = 220 \times \left(\frac{e^z - e^{-z}}{e^z + e^{-z}} \right)$	$e^z = \frac{F\eta - 1}{22}$ For free jump in expanding channel	(13)
Rectangular channel with smooth bed			
Smetana (1934)	$L_j = 6 \times H_j$	$H_j = y_2 - y_1$ For free jump in horizontal smooth bed	(14)
Safranez (1929)	$L_j = 6y_1 \times F\eta$	For free jump in horizontal smooth bed	(15)
Rectangular channel with rough bed			
Carollo <i>et al.</i> (2007)	$\frac{L_j}{y_1} = \left[6.525 \times \exp(-0.6 \frac{ks}{y_1}) \right] \times (F\eta - 1)$	For free jump in horizontal rough bed	(16)
	$Y = 0.5 \times \left[-1 + \sqrt{1 + 8 \times \left(1 - \frac{2}{\pi} \arctan[0.8 \left(\frac{ks}{y_1} \right)^{0.75}] \right) \times F\eta^2} \right]$		(17)
Tokyay (2005)	$Y = 1.1223 \times F\eta + 0.0365$	For free jump in horizontal rough bed	(18)
Naseri and Othman (2012)	$\frac{L_j}{y_1} = 9.75 \times (F\eta - 1)^{1.01}$	For free jump in horizontal rough bed	(19)

where $l_o, l_p, \bar{l}_o, \bar{l}_p, N$ respectively represent: the observed values, predicted values, mean observed values, mean predicted values and data numbers. The *RMSE* expresses the average difference among predicted and observed values, *R* enables information for linear relation among observation and corresponding estimated values. The coefficient R^2 is used for relative evaluating of the model capability in dimensionless quantities. A model with a small *RMSE* and higher R^2 and *R* is the most efficient model. Non-normalized data in estimation of the intended variable, may lead to undesirable results. Hence, all input variables were scaled to fall in the range of 0.1–1 to decrease the effect of the variables which have different absolute magnitudes. All data were normalized as following:

$$n_n = 0.1 + 0.9 \times \left(\frac{n - n_{\min}}{n_{\max} - n_{\min}} \right) \quad (23)$$

Which $n_n, n, n_{\max}, n_{\min}$ represent the normalized, the original, the maximum and minimum amount of parameter *n*, respectively.

3. SIMULATION AND MODELS DEVELOPMENT

3.1 Input Variables

In a data-driven model, selection of appropriate parameters as input variables is a crucial step during modeling process. The important parameters which affect the jump pattern are (Carollo *et al.*, 2007; Gandhi, 2014):

$$f(y_1, y_2, V_1, L_j, \mu, g, \rho, b_1, b_2, z, ks) = 0 \quad (24)$$

From dimensional analysis and considering y_1, g and μ as repeating variables, Eq. (24) can be expressed as following:

$$f\left(\frac{y_2}{y_1}, \frac{L_j}{y_1}, \frac{b_1}{y_1}, \frac{b_2}{y_1}, \frac{v_1^2}{gh_1}, \frac{\rho v_1 y_1}{\mu}, \frac{z}{y_1}, \frac{ks}{y_1}\right) = 0 \quad (25)$$

Equation (25) can be expressed as:

$$f\left(\frac{y_2}{y_1}, \frac{L_j}{y_1}, B, F\eta, R, \frac{z}{y_1}, \frac{ks}{y_1}\right) = 0 \quad (26)$$

in which $B = (b_1/b_2)$ is ratio of expansion.

Experimental studies by Elevatorski (2008) and Ranga Raju *et al.* (1980) revealed that hydraulic jump characteristics only depend on Froude number and Reynolds number has not significant impact on the prediction of hydraulic jump characteristics. Hager (1992) showed that the length of hydraulic jump depends on the height of jump and Froude number. Also, early experimental works have shown that the pitch ratio (w/ks) is an important parameter for flows on roughened beds where w is the distance between two roughness elements and ks is the height of roughness element. Therefore, in this study, different models based on upstream flow data and geometry of the channels were considered for modeling hydraulic jump characteristics. It should be noted that 80% of data were used for training and 20% of data were used for validating or testing the models. Table 3 shows the developed models in this study.

Table 3 The developed ANFIS models

Hydraulic jump characteristics			
Sequent depth ratio Y		Length of hydraulic jump L_j/y_1	
Model	Input variables	Model	Input variables
D(I)	Fr_1	L(I)	Fr_1
D(II)	$Fr_1, y_1/B$	L(II)	$Fr_1, (y_2-y_1)/y_1$
D(III)	$Fr_1, z/y_1$	L(III)	$Fr_1, y_2/y_1$
D(IV)	$Fr_1, ks/y_1$	L(IV)	$Fr_1, z/y_1$
D(V)	$Fr_1, w/ks$	L(V)	$Fr_1, ks/y_1$
-	-	L(VI)	$Fr_1, w/ks$

4. RESULTS AND DISCUSSION

4.1 Sequent Depth Ratio

For evaluating hydraulic jump characteristics in channels with different shapes and appurtenances, several models were developed according to the flow conditions and geometry of the applied channels and appurtenances. The ANFIS models were trained and tested to carry out the sequent depth ratio prediction in these channels. Table 4 and Fig. 3 show the results of ANFIS models. From the obtained results of statistical parameters (*RMSE*, *R* and *R*²) it can be stated that in the case of channels with smooth bed the superior performance was obtained for channel with sudden expanding walls. In this state, the model *D(II)* with parameters $Fr_1, y_1/B$ yielded the best results. For the case of channels with appurtenances, it was deduced that the developed models for channel with central block performed more successful than the other channels. In this state, the model *D(II)* with input parameters of Fr_1 and y_1/B led to more accurate outcome. According to the results, it could be stated that for channels with rough bed, using ks/y_1 parameter as input parameter caused an increment in models accuracy. Also, in rectangular basins, basin with rough bed presented better results than basin with step. From the results, it could be induced that expanding channel without any appurtenances led

to better prediction than rectangular channels with rough bed or with a step. Considering the results of the developed models for trapezoidal channel with rough bed, the model *D(V)* with parameters $Fr_1, w/ks$ presented higher accuracy. For this channel, it was observed that w/ks and ks/y_1 caused an increment in model efficiency and the impact of w/ks in increasing the accuracy of the model is more than ks/y_1 . Also, the model *D(I)* with only input parameter Fr_1 showed desired accuracy. It could be stated that the applied method can successfully predict the sequent depth ratio using only the upstream flow characteristic as input data. Figure 3 shows the comparison of observed and estimated sequent depth ratio of test series for the ANFIS superior model in each state.

4.2 Length of Hydraulic Jump

Table 5 summarizes the statistical criteria of all models of length of hydraulic jump in channels with different shapes. The table clearly shows that in the case of channels without appurtenances, channel with sudden expanding side walls led to better prediction accuracy in comparison to the rectangular channel, with the highest *R* and *R*² and the lowest *RMSE* values. For this case, the *L(II)* model with parameters $Fr_1, (y_2-y_1)/y_1$ represented higher accuracy. It could be inferred that adding $(y_2-y_1)/y_1$ and y_2/y_1 as model inputs increased the models efficiency. For basins with appurtenances, the *L(II)* model which includes $Fr_1, (y_2-y_1)/y_1$ as input parameters presented the best results, in which the expanding channel with a central block was used. Based on the results of basins with step indicated in Table 5, the sudden expanding channel yielded better results than rectangular channel. Also, it could be inferred that in rectangular basins, the basin with rough bed led to better predictions compared to the basin with a step. In trapezoidal channel with rough bed, the model *D(VI)* with parameters $Fr_1, w/ks$ was the superior model. It seems that using $w/ks, ks/y_1$ and z/y_1 as inputs caused an improvement in models accuracy. This issue demonstrates the influence of the geometry of the applied appurtenances (i.e. step, block and roughness elements) on the hydraulic characteristics in channels with different appurtenances. From the results listed in Tables 4 and 5 it could be induced that in both the sequent depth ratio and jump's length prediction process, the expanding channel models, without appurtenances, yielded better predictions in comparison with the rectangular channels with rough bed or with a step. For the case of expanding basins, it could be observed that the applied method can successfully predict the jump's length using only the upstream flow Froude number as input data. However, for prediction of jump's length among all basins, the basin with a central block performed more successfully than others. Figure 4 illustrates the experimental vs. simulated jump's length values of ANFIS best models in channels with different shapes for test series.

Table 4 Statistical parameters of the ANFIS models for the sequent depth ratio

Channel type	ANFIS Models	Performance criteria					
		Train			Test		
		R	R ²	RMSE	R	R ²	RMSE
Channel without appurtenances							
Rectangular channel with smooth bed	D(I)	0.981	0.935	0.043	0.972	0.910	0.048
Expanding channel with smooth bed	D(I)	0.958	0.916	0.050	0.945	0.882	0.056
	D(II)	0.977	0.952	0.041	0.955	0.915	0.046
Channel with appurtenances							
Rectangular channel with step	D(I)	0.825	0.735	0.078	0.814	0.718	0.079
	D(III)	0.922	0.807	0.062	0.902	0.804	0.072
Rectangular channel with rough bed	D(I)	0.828	0.777	0.071	0.825	0.752	0.075
	D(IV)	0.934	0.818	0.059	0.921	0.811	0.061
Expanding channel with step	D(I)	0.900	0.805	0.063	0.893	0.744	0.075
	D(II)	0.993	0.984	0.031	0.959	0.911	0.049
	D(III)	0.947	0.896	0.051	0.931	0.864	0.053
Expanding channel with central block	D(I)	0.984	0.961	0.035	0.975	0.944	0.042
	D(II)	0.994	0.987	0.026	0.993	0.985	0.029
	D(III)	0.985	0.967	0.033	0.979	0.957	0.037
Trapezoidal channel with rough bed	D(I)	0.936	0.927	0.045	0.958	0.913	0.047
	D(IV)	0.964	0.936	0.043	0.964	0.915	0.046
	D(V)	0.972	0.945	0.044	0.972	0.939	0.044

Fig. 5. Comparison of observed and predicted sequent depth ratio for the superior model. Table 5 Statistical parameters of the ANFIS models for jump's length.

Channel type	ANFIS Models	Performance criteria					
		Train			Test		
		R	R ²	RMSE	R	R ²	RMSE
Channel without appurtenances							
Rectangular channel with smooth bed	L(I)	0.855	0.681	0.078	0.834	0.652	0.079
	L(II)	0.879	0.756	0.067	0.876	0.721	0.068
	L(III)	0.872	0.751	0.069	0.871	0.719	0.071
Expanding channel with smooth bed	L(I)	0.903	0.812	0.062	0.855	0.720	0.067
	L(II)	0.908	0.839	0.044	0.898	0.808	0.047
	L(III)	0.907	0.818	0.046	0.855	0.771	0.065
Channel with appurtenances							
Rectangular channel with step	L(I)	0.635	0.561	0.131	0.621	0.502	0.138
	L(II)	0.925	0.845	0.046	0.921	0.752	0.058
	L(III)	0.839	0.802	0.071	0.824	0.738	0.073
	L(IV)	0.901	0.837	0.049	0.869	0.722	0.064
Rectangular channel with rough bed	L(I)	0.858	0.683	0.066	0.814	0.661	0.073
	L(II)	0.913	0.824	0.046	0.896	0.804	0.049
	L(III)	0.903	0.815	0.049	0.892	0.768	0.048
Expanding channel with step	L(V)	0.887	0.785	0.064	0.886	0.745	0.067
	L(I)	0.895	0.798	0.079	0.884	0.763	0.091
	L(II)	0.929	0.857	0.069	0.912	0.827	0.077
	L(III)	0.925	0.850	0.070	0.910	0.825	0.078
Expanding channel with central block	L(IV)	0.935	0.877	0.065	0.930	0.847	0.065
	L(I)	0.935	0.872	0.055	0.898	0.804	0.083
	L(II)	0.958	0.915	0.035	0.930	0.860	0.048
	L(III)	0.936	0.879	0.052	0.921	0.833	0.073
Trapezoidal channel with rough bed	L(IV)	0.932	0.867	0.056	0.923	0.848	0.064
	L(I)	0.909	0.822	0.072	0.904	0.804	0.085
	L(II)	0.912	0.831	0.067	0.909	0.811	0.082
	L(III)	0.910	0.825	0.069	0.906	0.809	0.084
	L(V)	0.938	0.879	0.059	0.927	0.857	0.073
	L(VI)	0.942	0.885	0.057	0.935	0.858	0.072

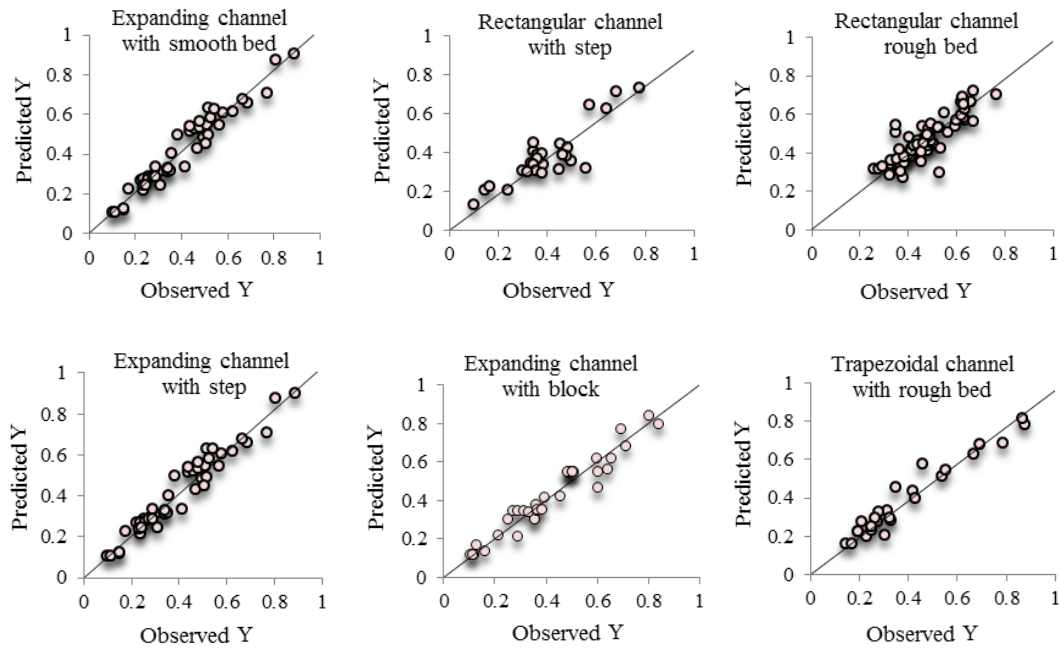

Fig. 3. Comparison of observed and predicted sequent depth ratio for the superior model

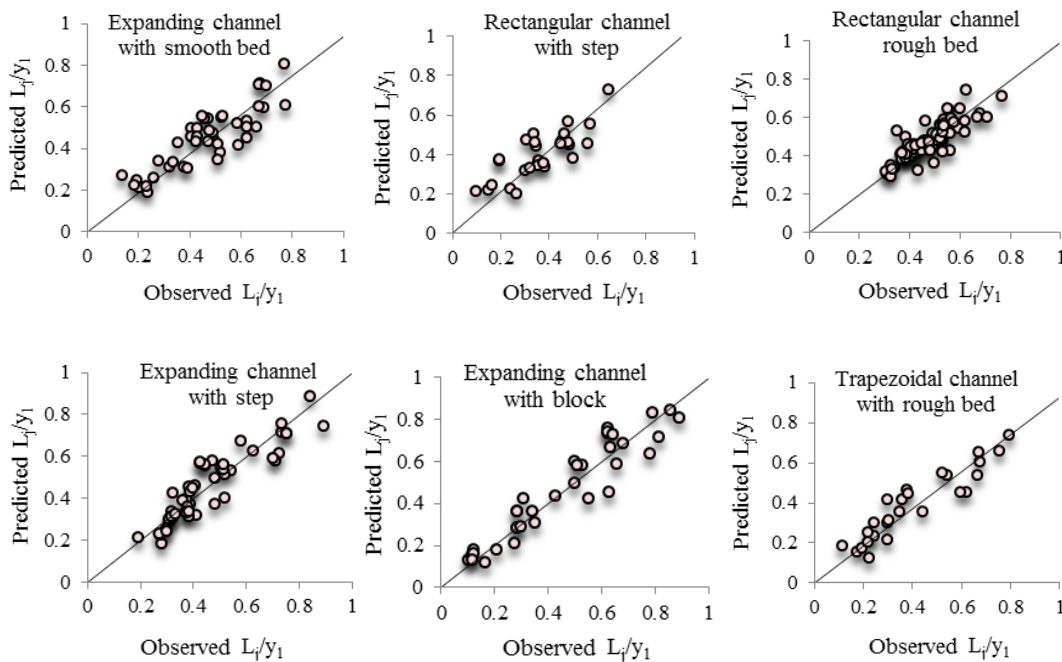

Fig. 4. Comparison of observed and predicted hydraulic jump's length for the superior model.

4.3 Sensitivity Analysis

In order to evaluate the significance of different employed variables of the ANFIS-best models on hydraulic jump characteristics, a sensitivity analysis was performed. The impact of each variable was assessed by removing it from the input set. Table 6 shows the results of sensitivity analysis of $D(II)$ and $L(II)$ models for channel with central block. The

table clearly shows that in predicting the both hydraulic jump characteristics (i.e. the sequent depth ratio and jump's length) Fr_1 is the most efficient parameter.

4.4 Comparison of the Best ANFIS Models with Classical Equations

The experimental data of test series were used to assess the capability of several existing formulas for

Table 6 Statistical parameters of the ANFIS models for combined data

Output variable	Model	Eliminated variable	Performance criteria					
			Train			Test		
			R	R ²	RMSE	R	R ²	RMSE
Y	D(II)	Fr ₁	0.724	0.601	0.101	0.714	0.581	0.115
		y ₁ /B	0.984	0.961	0.035	0.975	0.944	0.042
L _j /y ₁	L(II)	Fr ₁	0.445	0.278	0.159	0.408	0.289	0.178
		(y ₂ -y ₁)/y ₁	0.564	0.306	0.113	0.554	0.272	0.132

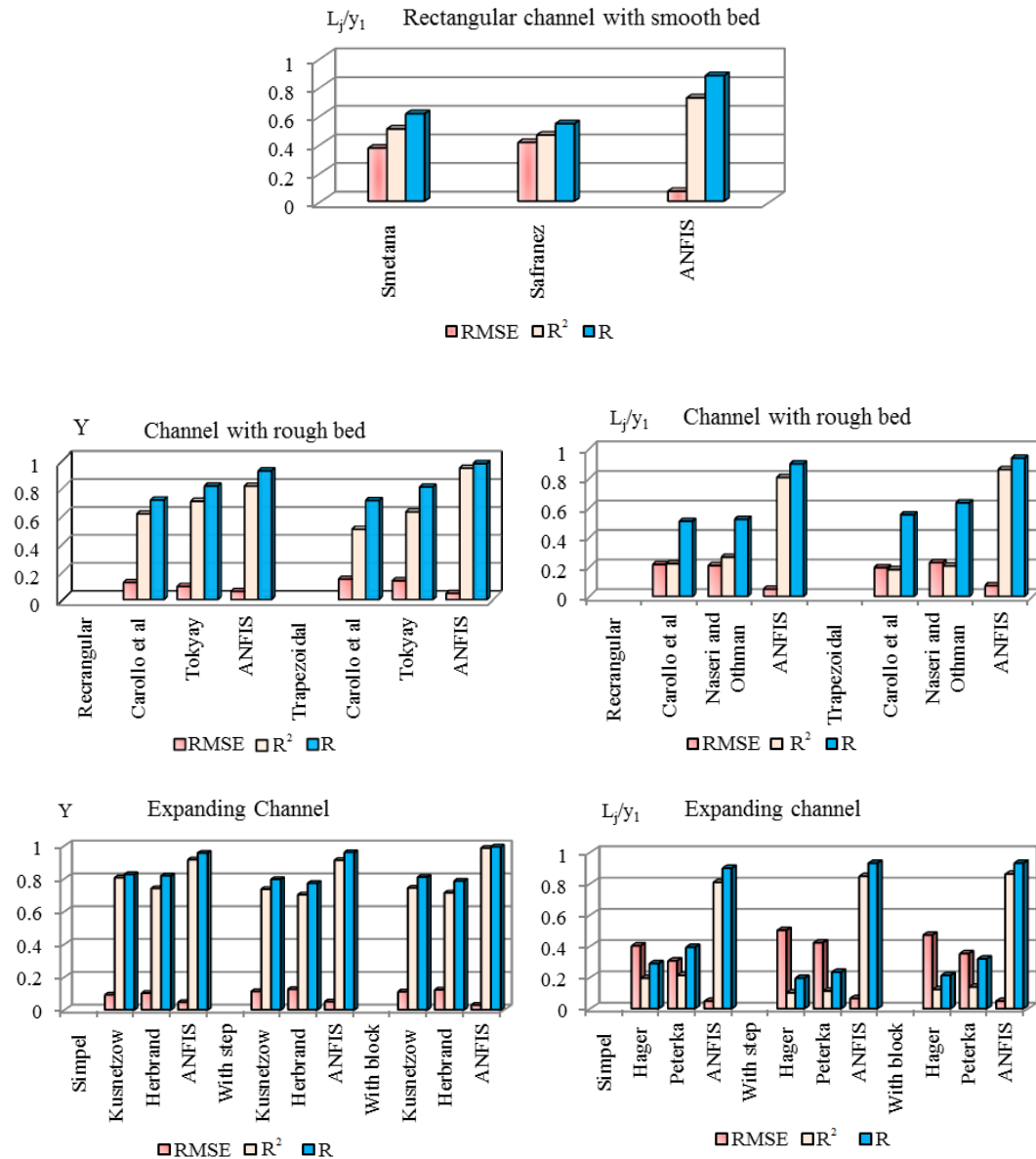

Fig. 5. Comparison of statistical parameters between formulas and best ANFIS models.

the sequence depth ratio and jump's length. The capability of each formula was evaluated using three performance criteria (R , R^2 , and $RMSE$). A comparison was performed among the best ANFIS models of channels with different shapes and appurtenances and those formulas. Figure 5 shows the comparison results. According to the obtained results, for all types of channels, the utilized equations for the sequent depth showed an

appropriate compatibility to the observed data, while the hydraulic jump's length formulas did not provided a good correlation between the estimated and observed values. However, for both hydraulic jump characteristics (i.e. Y , L_j/y_1) the results of the best ANFIS models were quite compatible with the experimental data and they were in good agreement. It should be noted that the existing equations are developed based on special flow conditions;

therefore, application of these equations is limited to special cases of their development and did not show uniform results under different conditions. This issue can be seen in Fig. 5. According to the obtained results, for channels with rough bed, [Carollo *et al.* \(2007\)](#), [Tokyay \(2005\)](#), and [Naseri and Othman \(2012\)](#) equations which have been developed for rectangular channels, presented better results in rectangular channels than trapezoidal channel. Also, in the cases of expanding channels, it could be inferred that the semi-empirical formulas led to better prediction in channel without appurtenance than channels with a central sill or a step. However, the obtained results confirmed the capability of ANFIS as a Meta model approach in predicting hydraulic jump characteristics in channels with different shapes and appurtenances.

5. CONCLUSION

In the current research, capability of the ANFIS method was assessed for estimating hydraulic jump characteristics (i.e. sequent depth ratio and jump's length) in channels with different boundary conditions. ANFIS was applied for different datasets in channels with smooth bed, rough bed, with a step and central block. The obtained results revealed that in predicting the sequent depth ratio the model including Fr_1 and y_1/B as input variables performed more successful than other models. The superior performance for length of hydraulic jump was obtained for the model with input parameters of Fr_1 and $(y_2 - y_1)/y_1$. Comparison between the results of channels with different shapes showed that the developed models for the case of channel with a central block led to more accurate outcome. For rectangular channels, it was also observed that the basin with roughness bed led to better predictions compared to the basin with a step. In predicting the hydraulic jump characteristics in trapezoidal channel with rough bed, the model with parameters Fr_1 , w/ks was the superior model. It was also found that adding w/ks , ks/y_1 and z/y_1 as input parameters caused an increment in models accuracy. This issue demonstrated the influence of the geometry of the applied appurtenances (i.e. step, block and roughness elements) on the hydraulic characteristics in channels with different appurtenances. The results showed that in both the sequent depth ratio and jump's length prediction process, the models of expanding channel without appurtenances lead to better estimations in comparison to the rectangular channels with rough bed or with a step.

Sensitivity analysis showed that among all input variables, Froude number (Fr_1) had the most significant impact on hydraulic jump characteristics estimation. It could be stated that the applied method is able to successfully predict the jump characteristics using only the upstream flow characteristics as input data. Comparison between ANFIS models and classical formulas confirmed the superior performance of ANFIS models over all of the formulas in modeling hydraulic jump characteristics in basins with different shapes and appurtenances.

REFERENCES

- Azamathulla, H. M., A. Ghani and Y. F. Seow. (2012). ANFIS-based approach for predicting sediment transport in clean sewer. *Applied Soft Computing* 12(3), 1227-1230.
- Bhutto, H. B. G. (1987). *Hydraulic jump control and energy dissipation*. (PhD Thesis), Mehran University of Engineering & Technology, Jamshoro.
- Bhutto, H., S. Mirani and S. Chandio. (1989). Characteristics of free hydraulic jump in rectangular channel. *Mehran University Research Journal of Engineering and Technology* 8(2), 34-44.
- Bremen, R. (1990). *Expanding Stilling Basin*. Laboratoire de Constructions Hydrauliques, Lausanne, Switzerland.
- Carollo, F. G., V. Ferro and V. Pampaloni. (2007). Hydraulic jumps on rough beds. *Journal of Hydraulic Engineering* 133(9), 989-999.
- Debabeche, M. and B. Achour. (2007). Effect of sill in the hydraulic jump in a triangular channel. *Journal of Hydraulic Research* 45(1), 135-139.
- Elevatorski, E. A. (2008). *Hydraulic Energy Dissipators*. McGraw-Hill, New York.
- Evcimen, T. U. (2012). *Effect of prismatic roughness on hydraulic jump in trapezoidal channels*. (Doctoral dissertation), Middle East Technical University.
- Ezizah, G., N. Yousif and S. Mostafa. (2012). Hydraulic jumps in new roughened beds. *Asian Journal of Applied Sciences* 5(2), 96-106.
- Gandhi, S. (2014). Characteristics of hydraulic Jump. *International Journal of Mathematical, Computational, Physical, Electrical and Computer Engineering* 8(4), 692-697.
- Hager, W. H. (1985). Hydraulic jumps in non-prismatic rectangular channels. *Journal of Hydraulic Research* 23(1), 21-35.
- Hager, W. H. (1992). *Energy Dissipators & Hydraulic Jumps*. Kluwer Academic Publication, Dordrecht, The Netherlands, pp. 151-173.
- Herbrand, K. (1973). The spatial hydraulic jump. *Journal of Hydraulic Research Delft* 11(3), 205-217.
- Karbasi, M and H. M. Azamathulla. (2016). Prediction of scour caused by 2D horizontal jets using soft computing techniques. *Ain Shams Engineering Journal* (In - Press).
- Kerachian, R., M. Karamouz and F. Soltany (2006). Optimal reservoir operation considering the water quality issues. Application of adaptive neuro fuzzy inference system. *Proc., ASCE World Water and Environmental Resources Congress*, ASCE, Reston, VA.
- Kisi, O. (2005). Suspended sediment estimation

- using neuro-fuzzy and neural network approaches. *Hydrological Sciences* 50(4), 683-696.
- Kisi, O. and J. Shiri (2012). River suspended sediment estimation by climatic variables implication: Comparative study among soft computing techniques. *Journal of Computers & Geosciences* 43, 73-82.
- Kusnetzow, S. K. (1958). Die Fliessbewegung bei plotzlicher verbreirerung des strombettes. *Gidrotechniceskoe Stroitelstvo* 27(6), 34-37.
- Naseri, M. and F. Othman. (2012). Determination of the length of hydraulic jumps using artificial neural networks. *Advances in Engineering Software* 48, 27-31.
- Negm, A. A. M. (2000). Hydraulic Performance of Rectangular and Radial Stilling Basins, *4th International Conference on Hydro-Science and Engineering*. Korea Water Resources Association, Korea.
- Ozger, M. and G. Yildirim. (2009). Determining turbulent flow friction coefficient using adaptive neuro-fuzzy computing technique. *Advanced Engineering Software* 40, 281-287 (2009)
- Peterka, A. J. (1958). *Hydraulic Design of Stilling Basins and Energy Dissipaters*. US Department Interior, Bureau of Reclamation, Engineering Monograph 25, Denver, CO.
- Ranga Raju, K. G., M. K.Mittal, M. S. Verma and V. R. Ganeshan. (1980). Analysis of flow over baffle blocks and end sills. *Journal of Hydraulic Research* 18(3), 227-241.
- Roushangar, K. and R. Ghasempour. (2016). Prediction of non-cohesive sediment transport in circular channels in deposition and limit of deposition states using SVM. *Journal of Water Science & Technology: Water Supply* 17(2), 537-551.
- Safranez, K. (1929). Untersuchung über den wechselfprung (Investigation on the hydraulic jump). *Der Bauingenieur*, Vol. 10, Heft 37, 649-651; Heft 38, 668-678.
- Saxena, S. and S. M. Yadav. (2017). *Neuro Fuzzy Application in Capacity Prediction and Forecasting Model for Ukai Reservoir*. In: Garg V., Singh V., Raj V. (eds) *Development of Water Resources in India*. Water Science and Technology Library, vol 75. Springer, Cham.
- Smetana, J. (1934). *Experimental study of the submerged or expanded hydraulic jump*. Report translated from the Russian by A.D. Kalal, Bureau of Reclamation, Denver, CO.
- Solgi, A., V. Nourani and A. Pourhaghi. (2014). Forecasting Daily Precipitation Using Hybrid Model of Wavelet-Artificial Neural Network and Comparison with Adaptive Neurofuzzy Inference System (Case Study: Verayneh Station, Nahavand). *Advances in Civil Engineering* vol. 2014, Article ID 279368, 12 pages.
- Sultana, A. (2011). *Study of hydraulic jump in a sloping channel with abrupt drop*. (M.S. Thesis), Bangladesh University of Engineering and Technology.
- Takagi, T. and M. Sugeno. (1985). Fuzzy identification of systems and its applications to modeling and control. *Proceedings of the IEEE Transactions on Systems, Man and Cybernetics* 15, 116-132.
- Talei, A., L. H. C. Chua and T. S. W Wong. (2010). Evaluation of rainfall and discharge inputs used by Adaptive Network based Fuzzy Inference Systems (ANFIS) in rainfall-runoff modeling. *Journal of Hydrology* 391, 248-262.
- Tokyay, N. D. (2005). Effects of channel bed roughness on hydraulic jumps. *Proc., ASCE World Water and Environmental Resources Congress*, ASCE, Reston, VA.